

**Assembly Instructions**

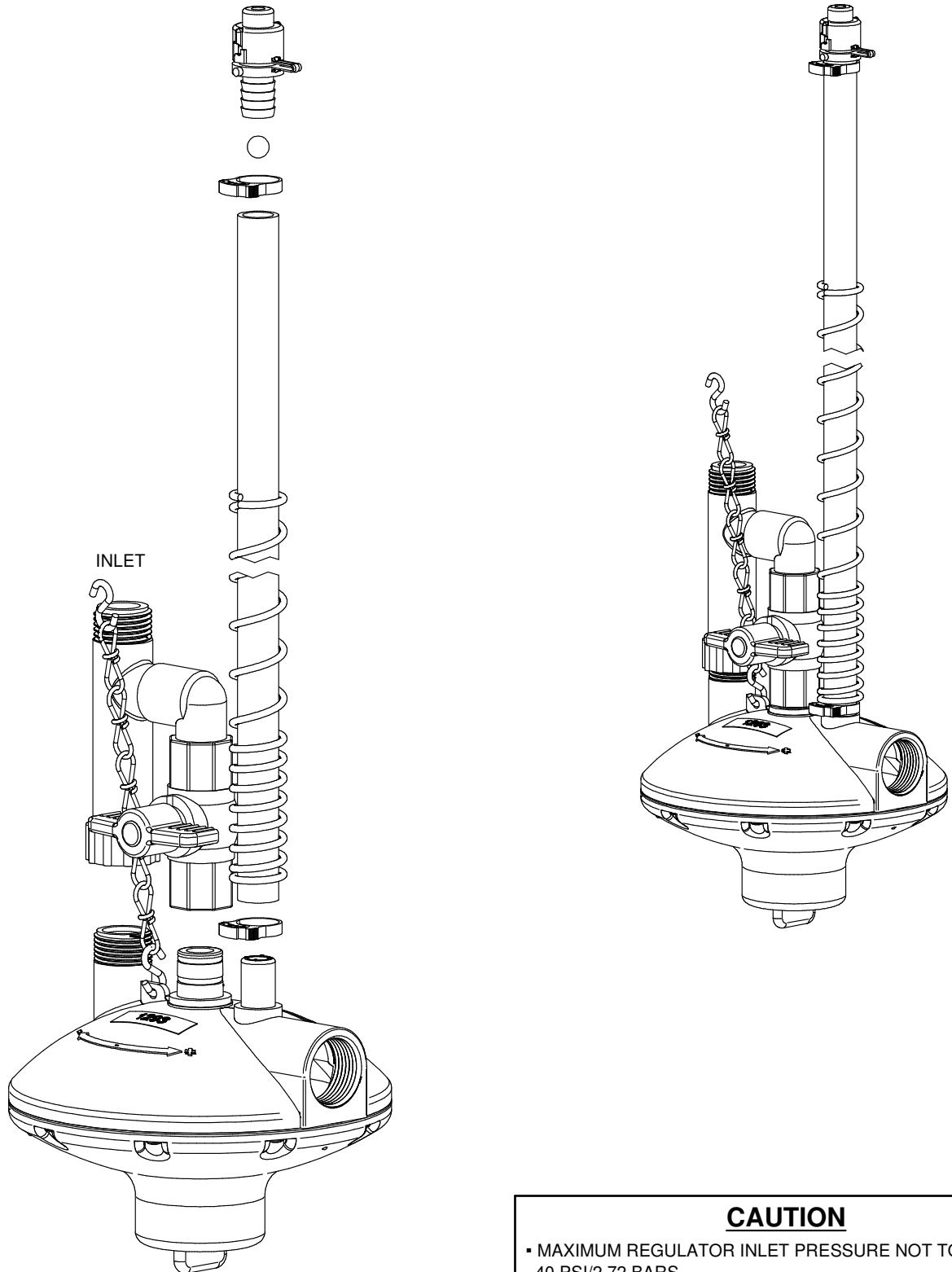

**CAUTION**

- MAXIMUM REGULATOR INLET PRESSURE NOT TO EXCEED 40 PSI/2.72 BARS.
- DO NOT ALLOW THIS ITEM TO COME INTO CONTACT WITH PETROLEUM, PHENOL OR ALDEHYDE BASED PRODUCTS OR ANY OTHER CORROSIVE PRODUCT IN GENERAL.

# COMPONENTS

| PART NR. | QTY | DESCRIPTION   |
|----------|-----|---|
| 122-24   | 1   | RISER TUBE: 24" / 60 CM   |
| 1374     | 1   | REGULATOR PART: FLUSH UNIT MHT INLET WHITE                          |
| 147      | 1   | BALL: RISER TUBE  |
| 1895     | 1   | SPRING: RISER TUBE  |
| 2005     | 1   | RISER TUBE CAP  |
| 1358     | 1   | REGULATOR PART: INLET/OUTLET HOUSING - CAGE 1" FNPT                 |
| 171      | 1   | REGULATOR PART: ADJUSTMENT KNOB ASSEMBLY - STANDARD                 |
| 187      | 1   | REGULATOR PART: ADJUSTMENT HOUSING - STANDARD & INLINE              |
| 157      | 1   | WASHER: METAL - 5/16" ID X 3/4" OD X 0.044" TH                      |
| 181      | 1   | REGULATOR PART: DIAPHRAGM - STANDARD                                |
| 417      | 1   | O-RING: 6.40MM ID X 10.21MM OD X 1.90MM CS                          |
| 89       | 1   | FASTENER: NUT HEX 5/16"-18 X 1/2" WD X 17/64" H                     |
| 91       | 1   | REGULATOR PART: SWIVEL COUPLING - STANDARD                          |
| 92       | 1   | REGULATOR PART: SHOULDER BOLT - STANDARD                            |
| 97       | 1   | REGULATOR PART: DIAPHRAGM BACKING PLATE - STANDARD                  |
| 506      | 1   | REGULATOR PART: SPRING 0.05 - 1 PSI                                 |
| 83       | 11  | FASTENER: SCREW PAN HD PHILLIPS #7 - 18 X 1/2" LG - PLASTITE THREAD |
| 87       | 2   | REGULATOR PART: RETAINER BLOCK - STANDARD                           |
| 888      | 1   | REGULATOR PART: OPENING ARM W/ SEAT                                 |
| 511      | 2   | CLAMP: SNAP 0.746" - 0.848" DIA. - BLACK                            |
| 766      | 2   | S-HOOK: 1"  |
| 767      | 1   | CHAIN: DOUBLE LOOP #3 X 36" / 92 CM                                 |

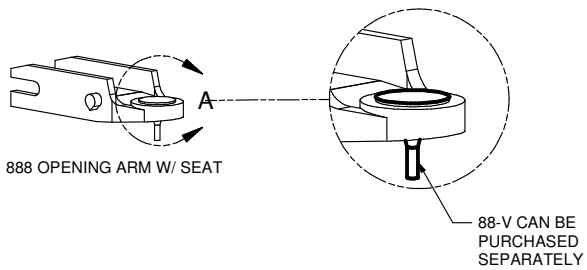
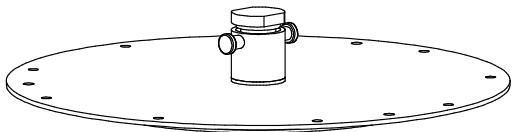
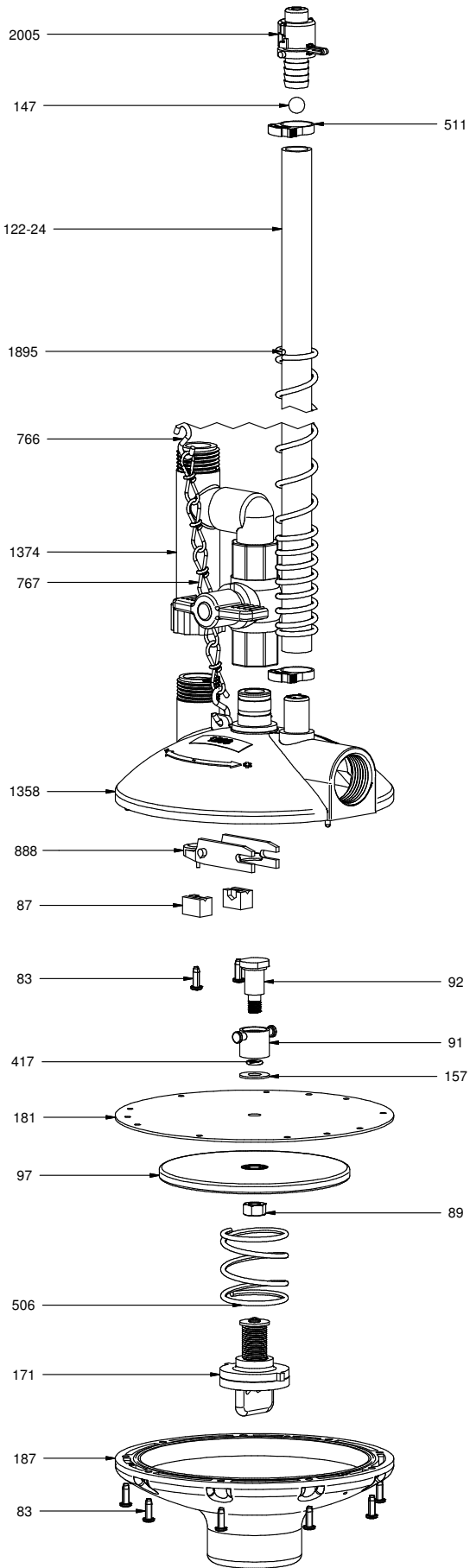



P.O. Box 1169  
101 Industrial Parkway  
Middlebury, Indiana  
46540-1169, USA  
Tel: + 1 574.825.5849  
Fax: + 1 574.825.7674  
Web: www.ziggity.com