

Assembly Layout

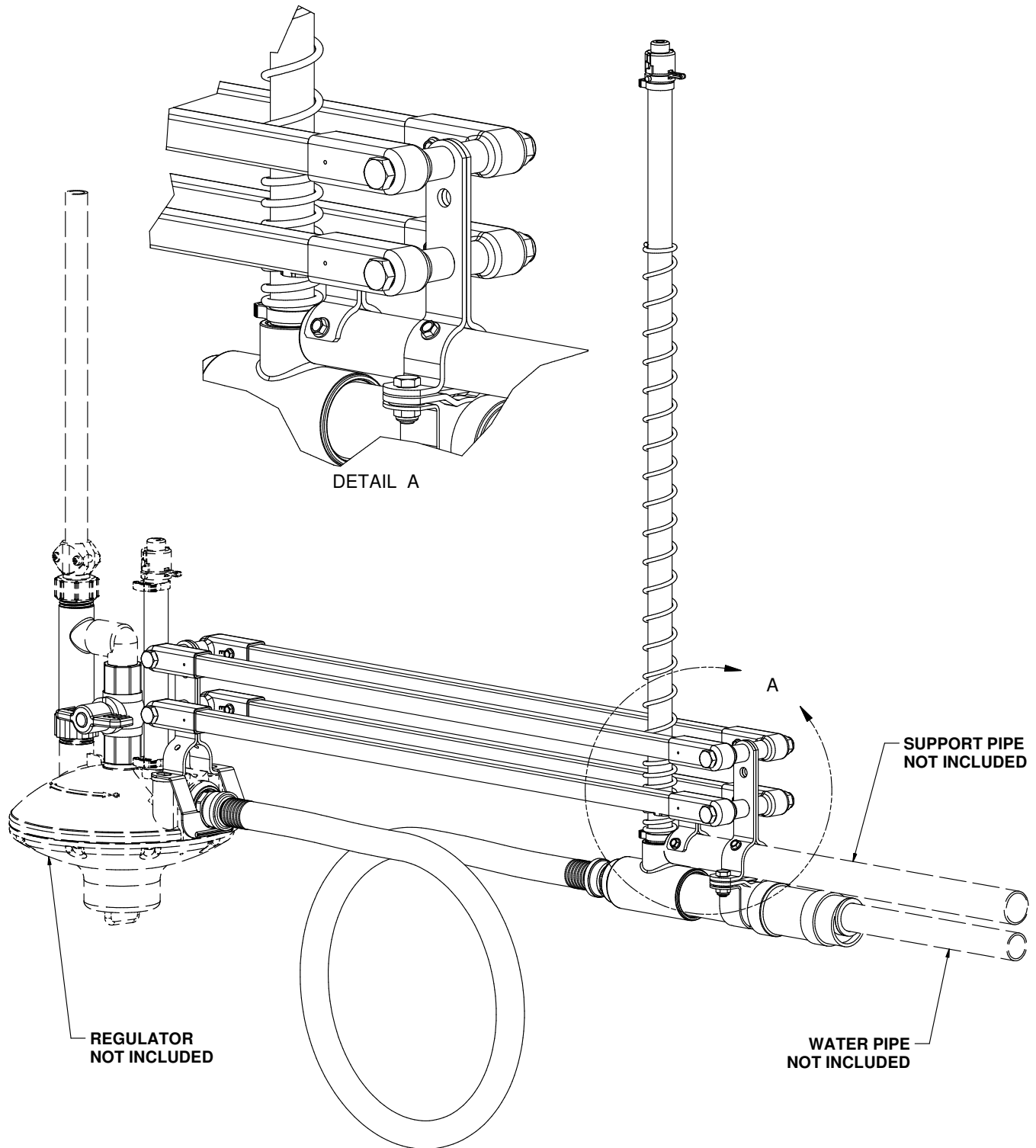

CAUTION
DO NOT ALLOW THIS ITEM TO COME INTO CONTACT WITH PETROLEUM, PHENOL OR ALDEHYDE BASED PRODUCTS OR ANY OTHER CORROSIVE PRODUCT IN GENERAL

COMPONENTS

PART NR.	QTY	DESCRIPTION
122-24	1	RISER TUBE: 24" / 60 CM
122-6	1	RISER TUBE: 6" / 15 CM
1369	1	ADAPTER: BIG ACE SPIGOT X ACE SLIP
147	1	BALL: RISER TUBE
1895	1	SPRING: RISER TUBE
2005	1	RISER TUBE CAP
2089	2	FASTENER: BOLT HEX HD M6 X 1 X 16 LG
2537	3	FASTENER: SCREW HEX WHD SELF TAPPING #8-18 X 1/2" LG
2778	4	PRESSURE PRO ASSEMBLY PART: ROD UNIT
2779	1	PRESSURE PRO ASSEMBLY PART: AIR RELEASE STABILIZER BRACKET
2780	1	PRESSURE PRO ASSEMBLY PART: AIR RELEASE U-CLAMP
2781	1	PRESSURE PRO ASSEMBLY PART: ROD SUPPORT
2782	4	FASTENER: BOLT HEX HD PT M8 X 1.25 X 90 LG
2783	4	FASTENER: NUT LOCK HEX M8 X 1.25
2786	1	PRESSURE PRO ASSEMBLY PART: AIR RELEASE UNIT
2788	1	PRESSURE PRO ASSEMBLY PART: BIG ACE SPIGOT X MHT
2789	1	PRESSURE PRO ASSEMBLY PART: HOSE W/ FHT
2791	2	FASTENER: NUT LOCK HEX M6 X 1.00
2792	2	WASHER: METAL - 9/32" ID X 5/8" OD X 0.050" TH
2836	1	PRESSURE PRO ASSEMBLY PART: BUSHING RETAINING CLAMP
511	2	CLAMP: SNAP 0.746" - 0.848" DIA.
896	1	PIPE CONNECTOR: BIG ACE - BLACK
898	2	CLAMP: SUPPORT PIPE TO FLOOR REGULATOR

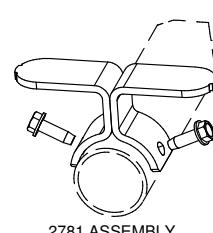
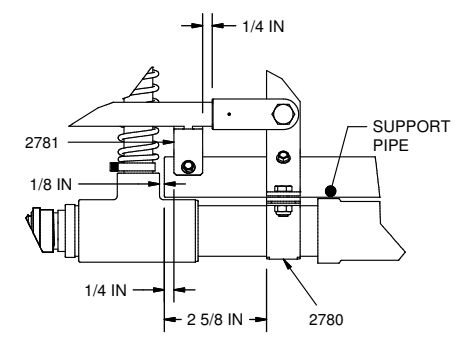
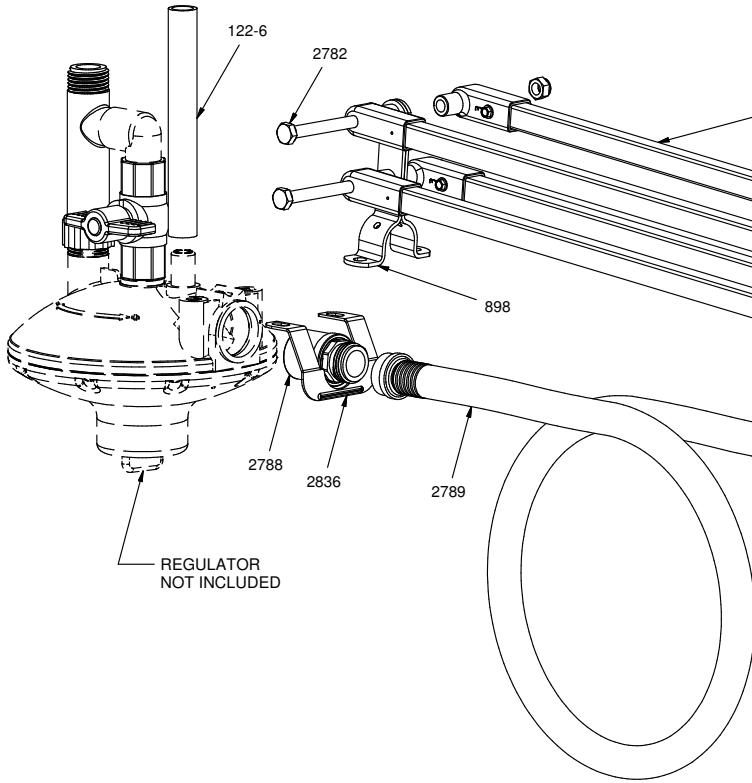
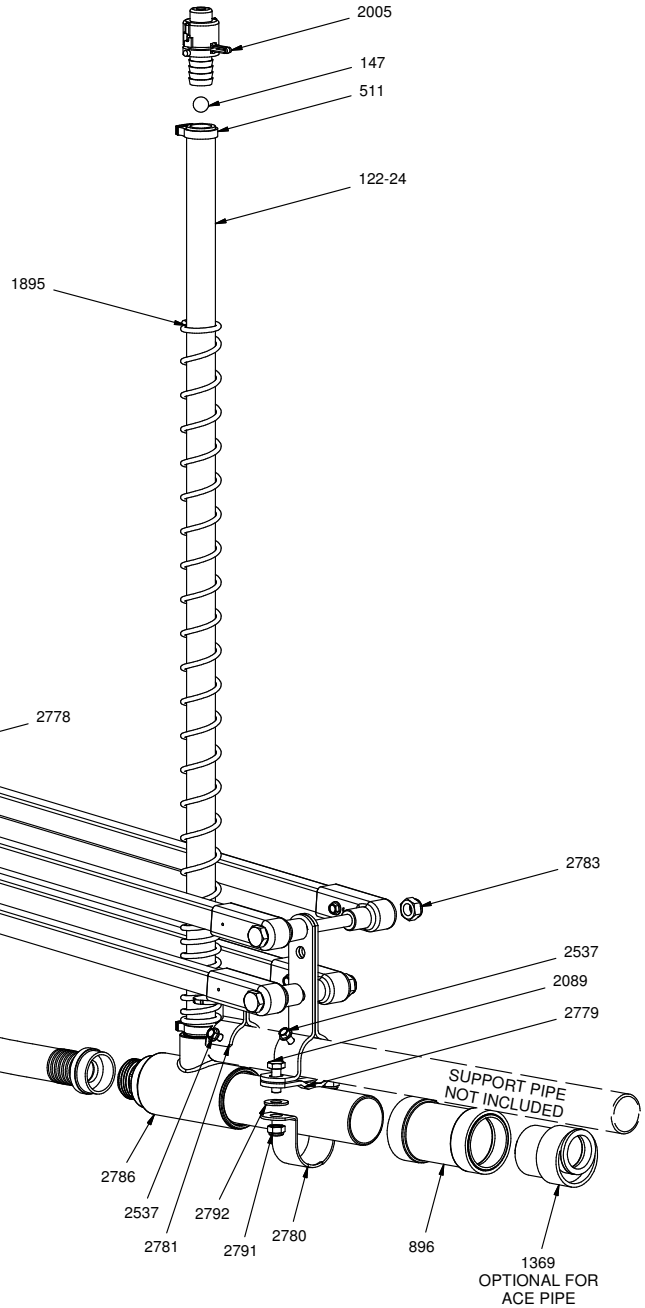

P.O. Box 1169
 101 Industrial Parkway
 Middlebury, Indiana
 46540-1169, USA
 Tel: + 1 574.825.5849
 Fax: + 1 574.825.7674
 Web: www.ziggity.com