

REGULATOR ASSEMBLY KEY:

- CLASSIC** = REGULATOR ASSEMBLY TOP WITH RISER
- NUVO** = REGULATOR ASSEMBLY TOP WITHOUT RISER
- FLUSH** = MANUAL FLUSH FEATURE
- AUTO FLUSH** = SOLENOID FLUSH FEATURE
- NAV** = NORTH AMERICAN VERSION "MHT"
- IV** = INTERNATIONAL VERSION "3/4" NPT"
- APA** = ACE PIPE ADAPTER
- ARF** = ADJUSTMENT RESISTANCE FEATURE
- LPR** = LOW PRESSURE RANGE

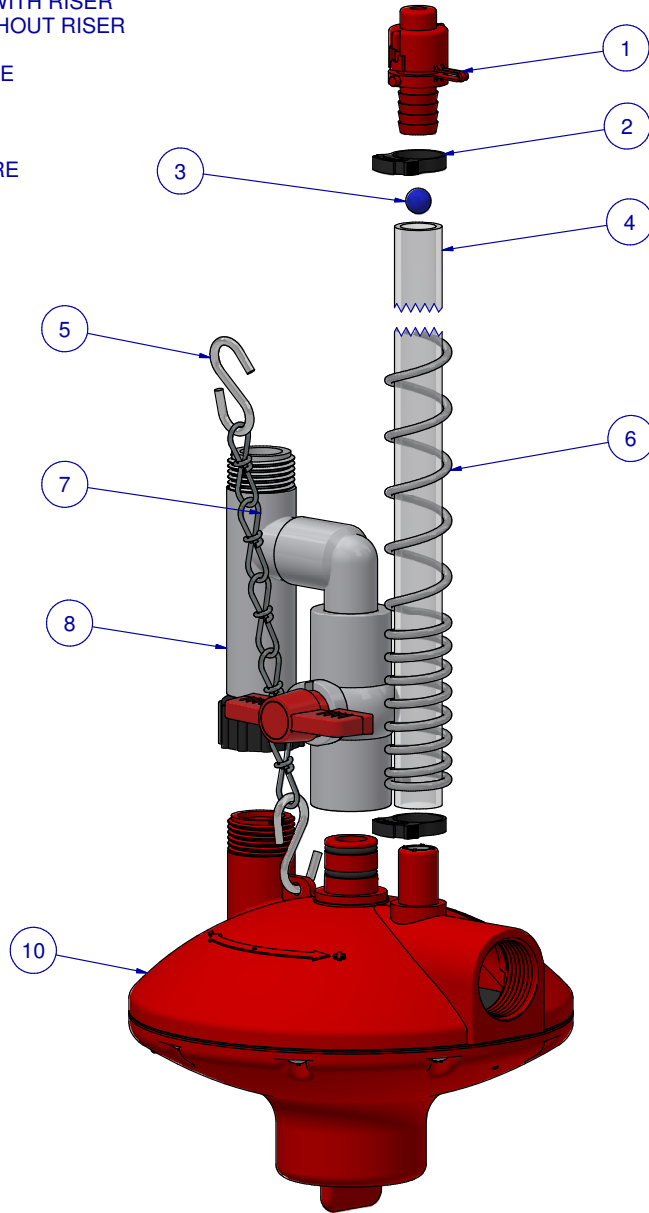

ITEM	PART NR.	QTY	DESCRIPTION
1	2005	1	RISER TUBE CAP
2	511	2	CLAMP: SNAP 0.746" - 0.848" DIA. - BLACK
3	147	1	BALL: RISER TUBE
4	122-24	1	RISER TUBE: 24" / 60 CM
5	2765	2	S-HOOK: ANTI-ROOST CABLE ANCHOR
6	1895	1	SPRING: RISER TUBE
7	767	1	CHAIN: DOUBLE LOOP #3 X 36" / 92 CM
8	1374	1	REGULATOR PART: FLUSH UNIT MHT INLET WHITE
10	2350	1	REGULATOR ASSEMBLY PART: UNIT CLASSIC / THREADED OUTLET

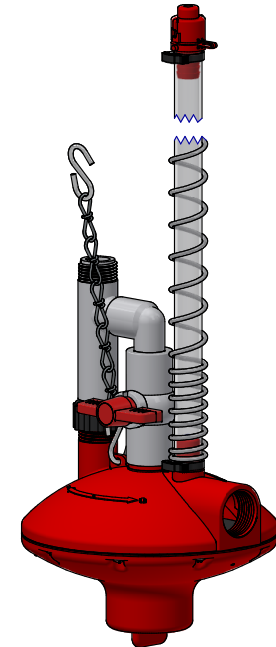

REGULATOR ASSEMBLY: CLASSIC - FLUSH / NAV / THREADED OUTLET

PART NR.:

DATE: 03-13-01

REVISION: 2

1293