

**REGULATOR ASSEMBLY KEY:**

- CLASSIC** = REGULATOR ASSEMBLY TOP WITH RISER
- NUVO** = REGULATOR ASSEMBLY TOP WITHOUT RISER
- FLUSH** = MANUAL FLUSH FEATURE
- AUTO FLUSH** = SOLENOID FLUSH FEATURE
- NAV** = NORTH AMERICAN VERSION "MHT"
- IV** = INTERNATIONAL VERSION "3/4" NPT"
- APA** = ACE PIPE ADAPTER
- ARF** = ADJUSTMENT RESISTANCE FEATURE
- PLF** = PRESSURE LIMITER FEATURE
- LPR** = LOW PRESSURE RANGE

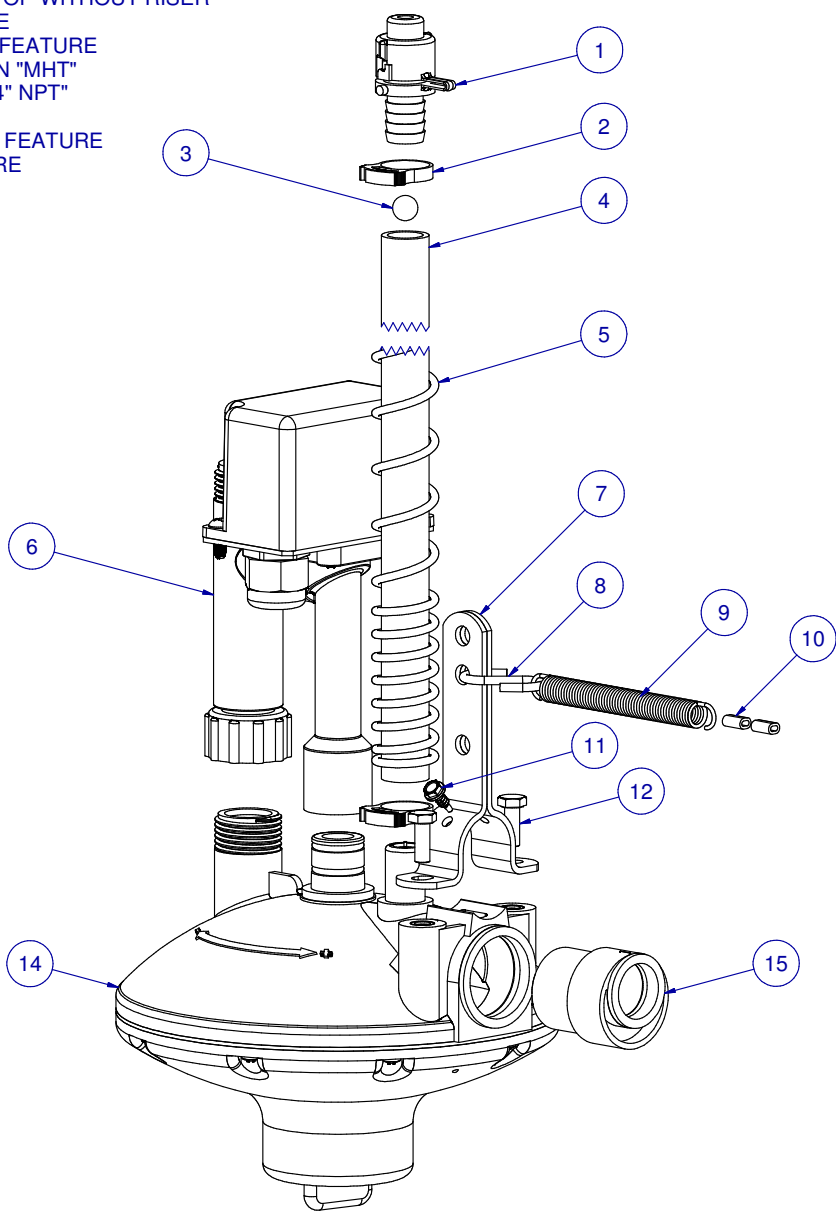

ITEM	PART NR.	QTY	DESCRIPTION
1	2005	1	RISER TUBE CAP
2	511	2	CLAMP: SNAP 0.746" - 0.848" DIA. - BLACK
3	147	1	BALL: RISER TUBE
4	122-24	1	RISER TUBE: 24" / 60 CM
5	1895	1	SPRING: RISER TUBE
6	1573	1	REGULATOR PART: SOLENOID FLUSH MHT INLET - 24 VAC
7	898	1	CLAMP: SUPPORT PIPE TO FLOOR REGULATOR
8	2765	1	S-HOOK: ANTI-ROOST CABLE ANCHOR
9	206	1	SPRING: ANTI-ROOST
10	207	2	CLIP: ANTI-ROOST CABLE
11	2537	1	FASTENER: SCREW HEX WHD SELF TAPPING #8-18 X 1/2" LG
12	2089	2	FASTENER: BOLT HEX HD M6 X 1 X 16 LG
14	2349	1	REGULATOR ASSEMBLY PART: UNIT CLASSIC
15	1369	1	ADAPTER: BIG ACE SPIGOT X ACE SLIP

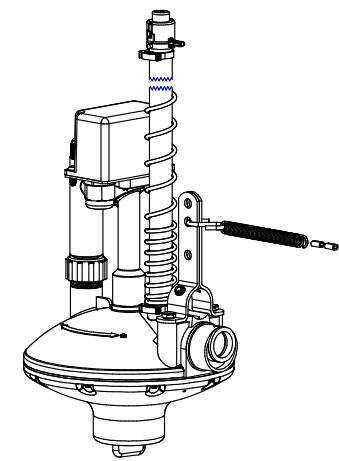

REGULATOR ASSEMBLY: CLASSIC - AUTO  
FLUSH / NAV / APA

PART NR.:

DATE: 05-23-23

REVISION: 1

4182