

Assembly Instructions

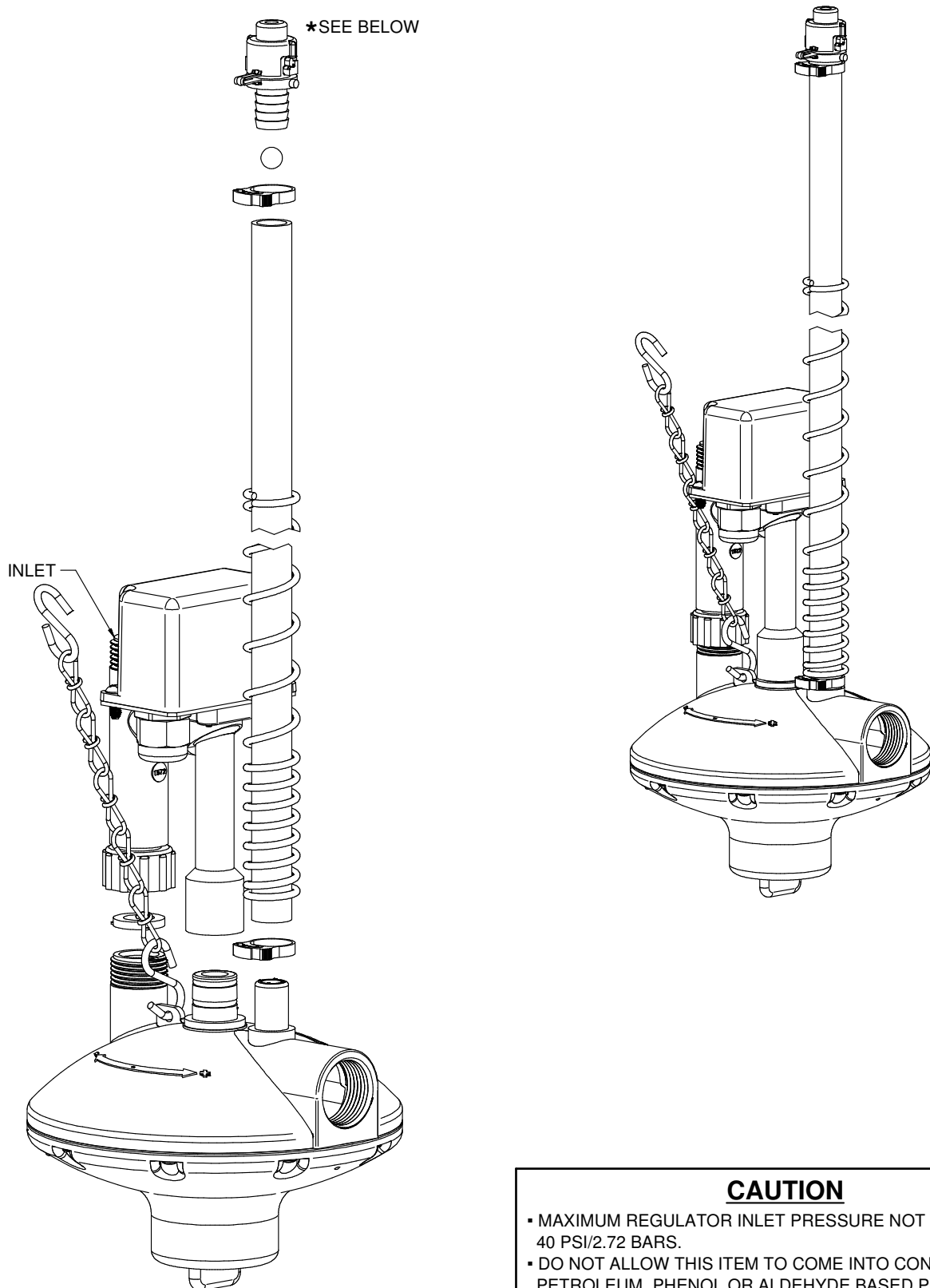

CAUTION

- MAXIMUM REGULATOR INLET PRESSURE NOT TO EXCEED 40 PSI/2.72 BARS.
- DO NOT ALLOW THIS ITEM TO COME INTO CONTACT WITH PETROLEUM, PHENOL OR ALDEHYDE BASED PRODUCTS OR ANY OTHER CORROSIVE PRODUCT IN GENERAL.
- IF PRESSURE DURING FLUSHING IS BELOW 5 PSI/0.35 BAR SEE GL1089

1613 COMPONENTS

PART NR.	QTY	DESCRIPTION
122-24	1	RISER TUBE: 24" / 60 CM
147	1	BALL: RISER TUBE
1573	1	REGULATOR PART: SOLENOID FLUSH MHT INLET - 24 VAC
1895	1	SPRING: RISER TUBE
2005	1	RISER TUBE CAP
1358	1	REGULATOR PART: INLET/OUTLET HOUSING - CAGE 1" FNPT
171	1	REGULATOR PART: ADJUSTMENT KNOB ASSEMBLY - STANDARD
187	1	REGULATOR PART: ADJUSTMENT HOUSING - STANDARD & INLINE
157	1	WASHER: METAL - 5/16" ID X 3/4" OD X 0.044" TH
181	1	REGULATOR PART: DIAPHRAGM - STANDARD
417	1	O-RING: 6.40MM ID X 10.21MM OD X 1.90MM CS
89	1	FASTENER: NUT HEX 5/16" - 18 X 1/2" WD X 17/64" H
91	1	REGULATOR PART: SWIVEL COUPLING - STANDARD
92	1	REGULATOR PART: SHOULDER BOLT - STANDARD
97	1	REGULATOR PART: DIAPHRAGM BACKING PLATE - STANDARD
506	1	REGULATOR PART: SPRING 0.05 - 1 PSI
83	11	FASTENER: SCREW PAN HD PHILLIPS #7 - 18 X 1/2" LG - PLASTITE THREAD
87	2	REGULATOR PART: RETAINER BLOCK - STANDARD
888	1	REGULATOR PART: OPENING ARM W/ SEAT
511	2	CLAMP: SNAP 0.746" - 0.848" DIA. - BLACK
767	1	CHAIN: DOUBLE LOOP #3 X 36" / 92 CM
2765	2	S-HOOK: ANTI-ROOST CABLE ANCHOR

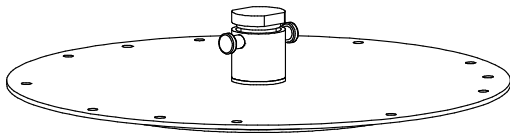
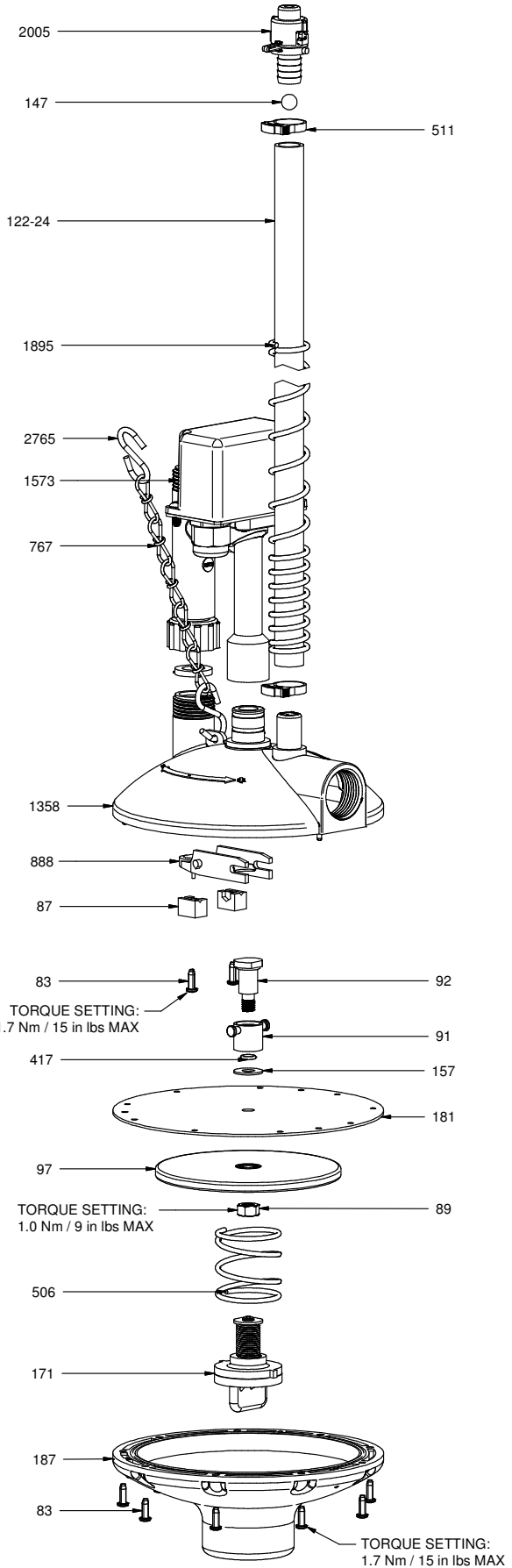

301 DIAPHRAGM ASSEMBLY - STANDARD

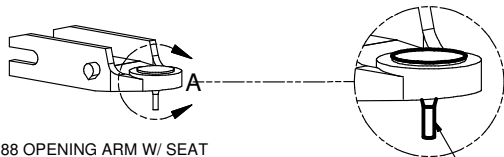

888 OPENING ARM W/ SEAT

88-V CAN BE PURCHASED SEPARATELY



Ziggy Systems Inc.
 101 Industrial Parkway East
 Middlebury Indiana 46540-8549
 USA
 Tel: + 1 574.825.5849
 Fax: + 1 574.825.7674
 Web: www.ziggy.com