

## Assembly Instructions

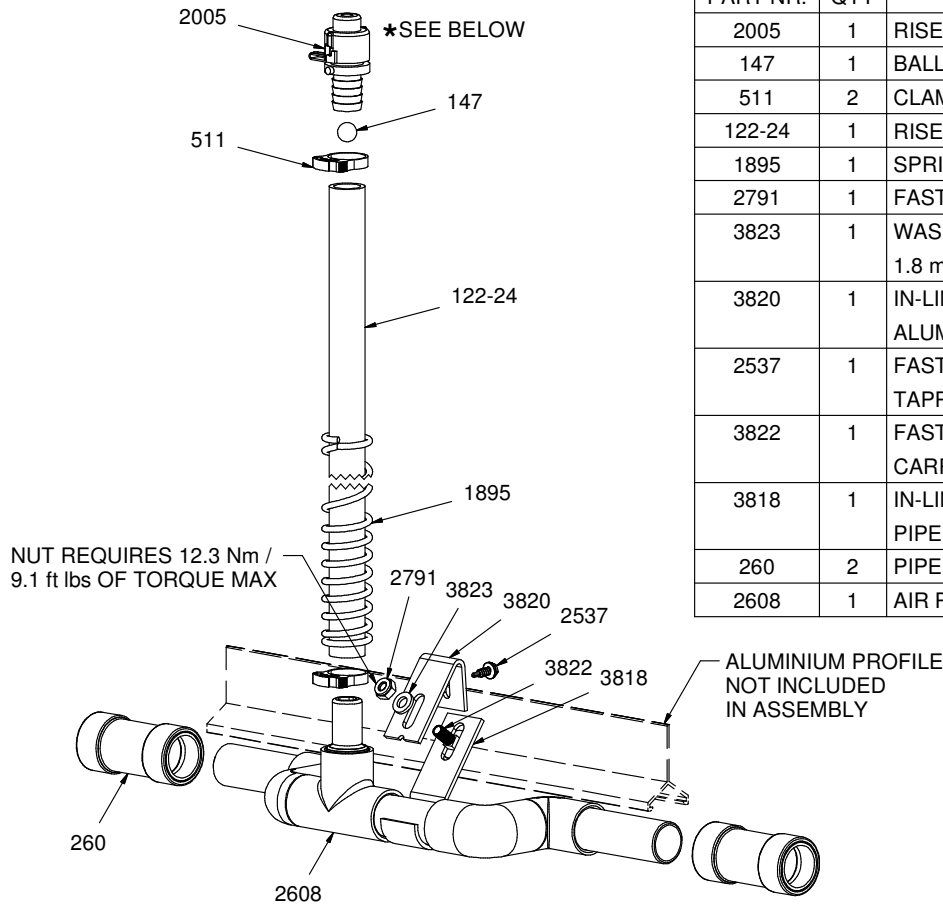

PART NR.	QTY	DESCRIPTION
2005	1	RISER TUBE CAP
147	1	BALL: RISER TUBE
511	2	CLAMP: SNAP 0.746" - 0.848" DIA. - BLACK
122-24	1	RISER TUBE: 24" / 60 CM
1895	1	SPRING: RISER TUBE
2791	1	FASTENER: NUT LOCK HEX M6 X 1.00
3823	1	WASHER: METAL - 6.4 mm ID X 12 mm OD X 1.8 mm TH
3820	1	IN-LINE FLOOR BRACKET ASSEMBLY PART: ALUMINIUM PROFILE INTERFACE - ACE
2537	1	FASTENER: SCREW HEX WHD SELF TAPPING #8-18 X 1/2" LG
3822	1	FASTENER: BOLT SQUARE-NECK CARRIAGE M6 X 1.0 X 16 mm LG
3818	1	IN-LINE FLOOR BRACKET ASSEMBLY PART: PIPE INTERFACE - ACE
260	2	PIPE CONNECTOR: ACE - WHITE
2608	1	AIR RELEASE UNIT: FLOOR ACE

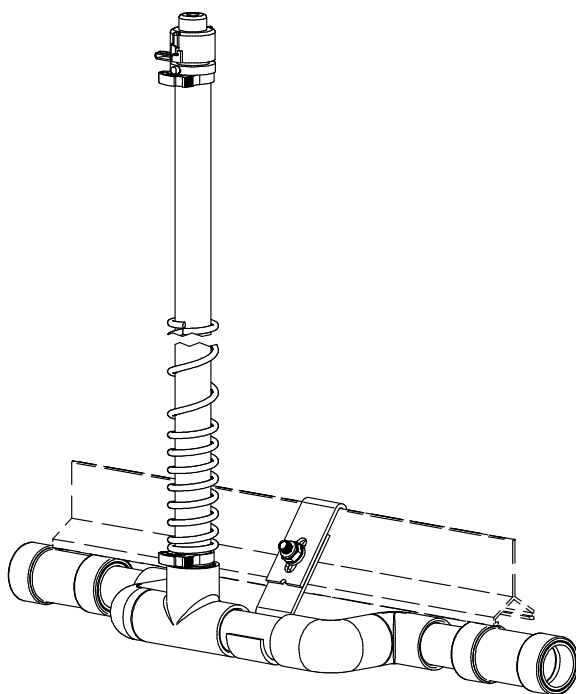

ASSEMBLED VIEW

### CAUTION

- DO NOT ALLOW THIS ITEM TO COME INTO CONTACT WITH PETROLEUM, PHENOL OR ALDEHYDE BASED PRODUCTS OR ANY OTHER CORROSIVE PRODUCT IN GENERAL.
- \*IF PRESSURE DURING FLUSHING IS BELOW 5 PSI/0.35 BAR SEE GL1089

# 3825 NEW INSTALLATION

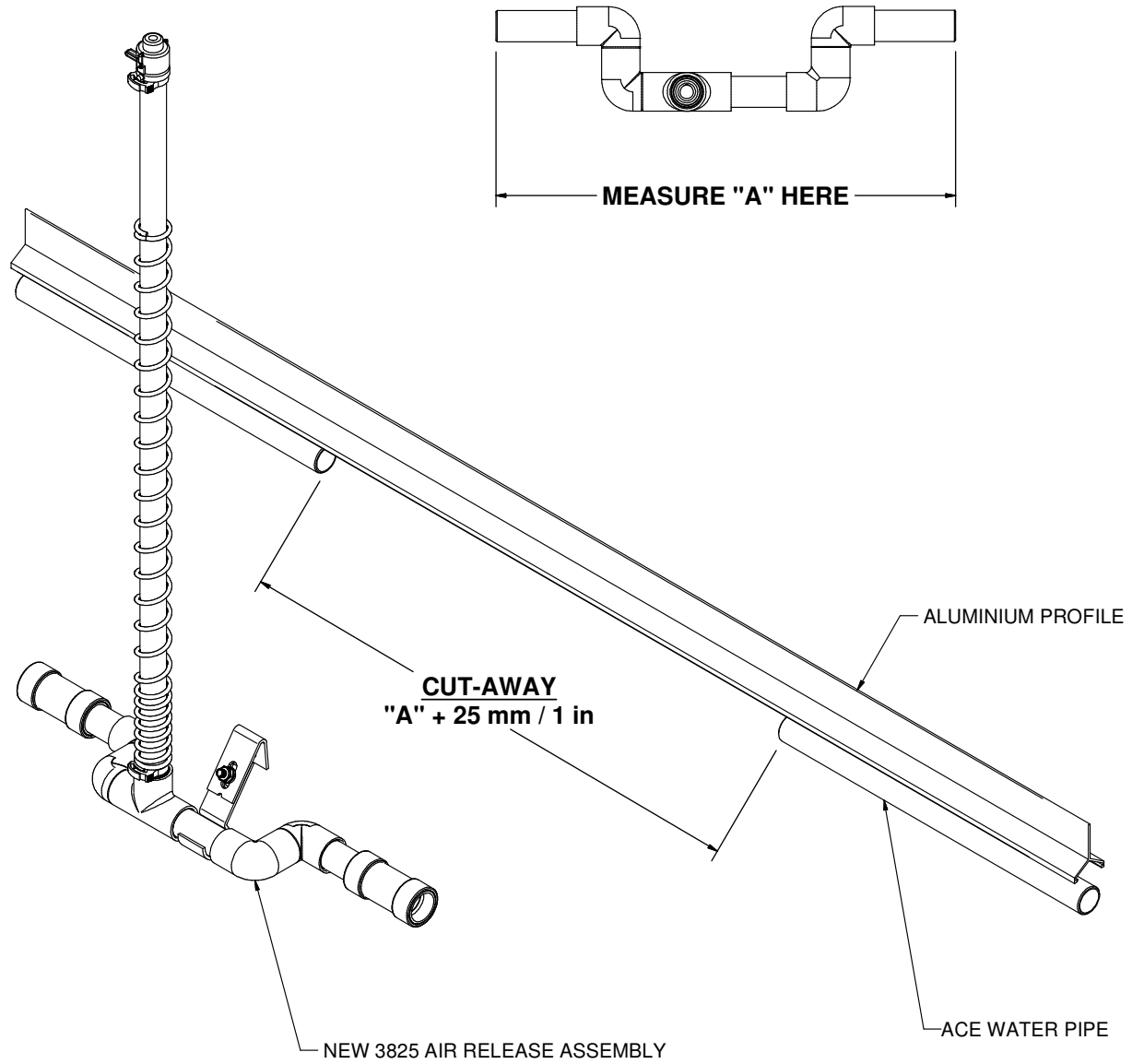

**ZIGGITY Z SYSTEMS INC.**

Ziggity Systems Inc.  
101 Industrial Parkway East  
Middlebury Indiana 46540-8549  
USA  
Tel: + 1 574.825.5849  
Fax: + 1 574.825.7674  
Web: www.ziggity.com